



Weld Quality

By Matt Scott

Common Terms

- ◆ Undercut
- ◆ Slag Inclusions
- ◆ Porosity
- ◆ Overlap Over Lap
- ◆ Cracks
- ◆ Weld Contour
- ◆ Incomplete Penetration
- ◆ Excessive Reinforcement
- ◆ Insufficient Reinforcement

Undercut

Undercut

- ◆ Is a condition where the base metal has been melted away during the welding operation and there is insufficient filler metal deposited to adequately fill the resulting depression.
- ◆ These grooves vary in depth and length.
- ◆ Undercut can be present at a weld-to-weld junction or a weld to base metal junction (toe of weld). Undercut causes a stress concentration point (stress riser) that is a potential starting point for weld cracking.



Slag Inclusions

Slag Inclusions

- ◆ Slag is a nonmetallic by product of the welding process. If slag is not cleaned out thoroughly before depositing the next pass it can be trapped. Or, if the previous weld(s) have poor weld profile slag can become trapped in the crevices when welded over.
- ◆ Improper cleaning, improper electrode manipulation or poor bead placement most often causes slag inclusions

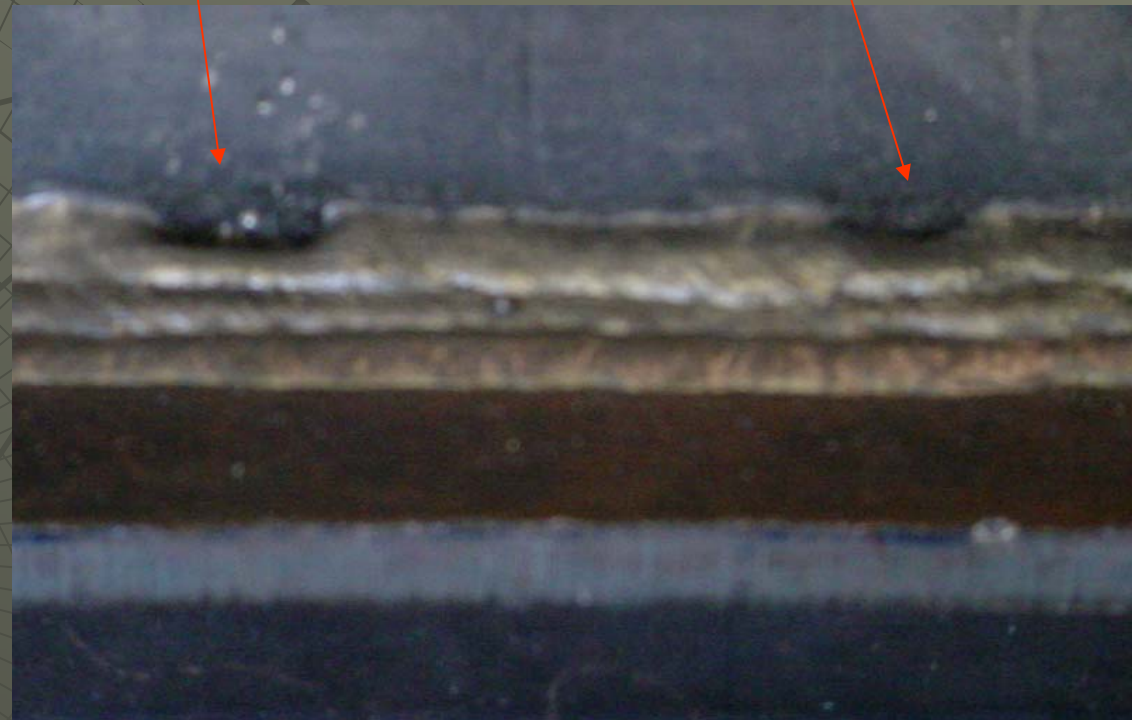

Porosity

Porosity

- ◆ A cavity type discontinuity caused by gas trapped during weld solidification.
- ◆ Due to its spherical shape, porosity is considered the least detrimental discontinuity.

Causes:

- ◆ Loss of shielding gas
- ◆ Base metal contamination (oils, grease, water)
- ◆ Too long of an arc length..

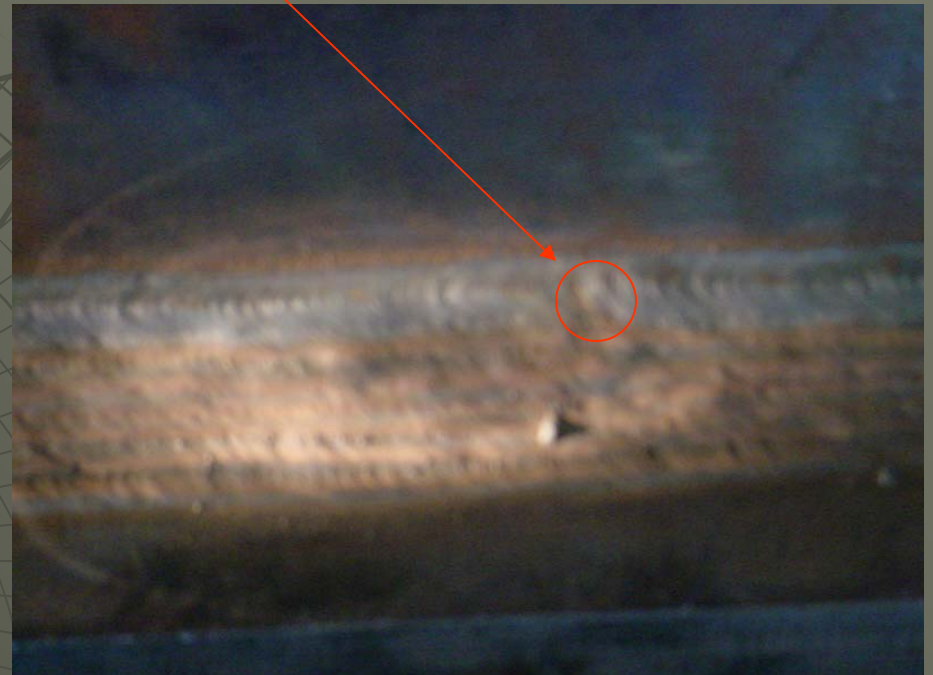

Overlap Overlap

- ◆ *Overlap (Also known as: Cold Lap, Roll Over or Cold Roll)*
- ◆ Is the protrusion of weld metal beyond the weld toe or root. Due to its linearity and relatively sharp end condition, overlap represents a significant weld discontinuity.



Cracks

- ◆ Cracks are caused by stresses in the immediate area that exceed the strength of weld metal or base metal (tensile strength).
- ◆ Cracks are a major concern because of their ends, which are generally sharp and jagged. With increased stress, the crack can then propagate (travel) in the weld or base metal causing catastrophic (total) failure.

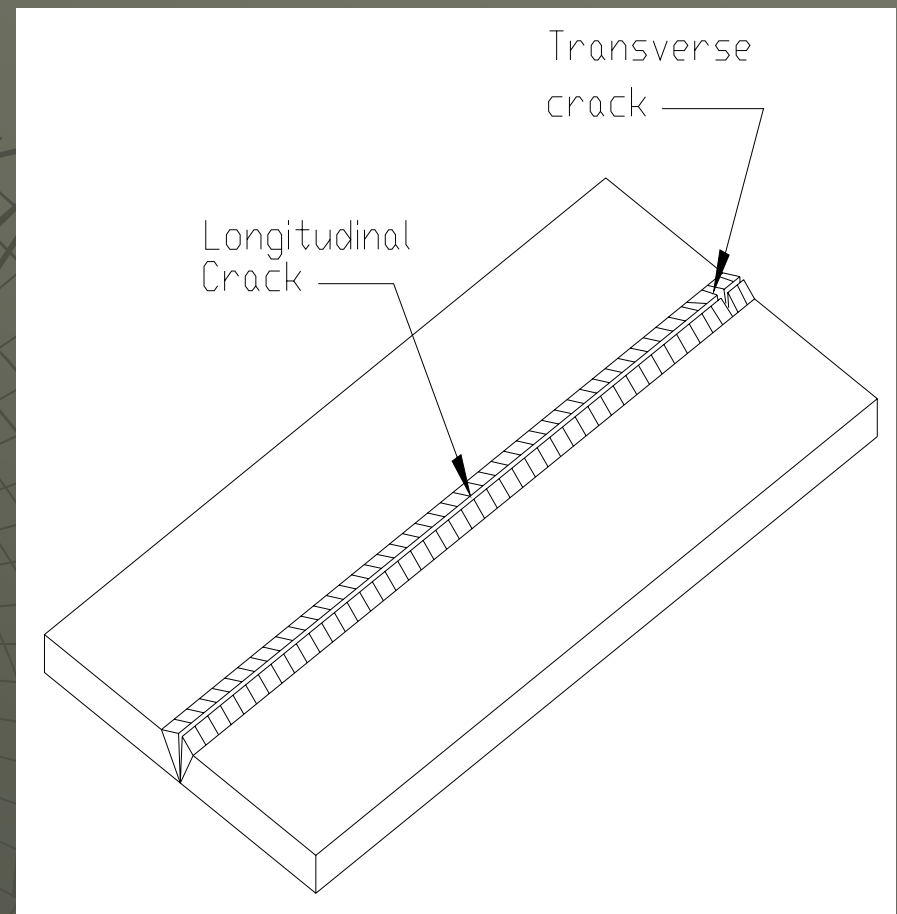

Weld Contour

- ◆ Per AWS D1.1, requirements a smooth transition between the weld metal and base metal is needed.



Incomplete Penetration

- ◆ Incomplete penetration is where the weld metal does not fully consume the root edge and therefore leaving a straight line. This line can be seen by removing the back strap or by using a NDT method such as UT or RT.

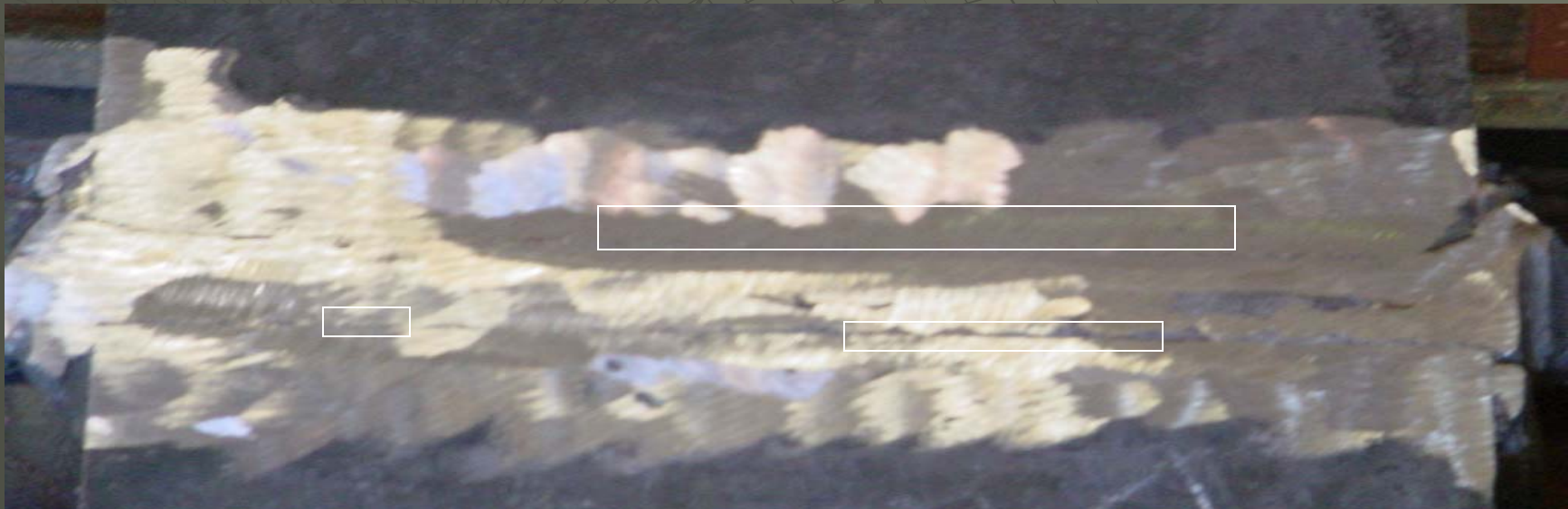

Excessive Reinforcement

- ◆ Too much weld!
AWS D1.1 states that weld reinforcement must equal the thickness of the base metal to a maximum of 1/8" above the base metal.



Insufficient Reinforcement

- ◆ Insufficient reinforcement can be seen by the lack of fill. Pictured here is a corner joint where the weld is “flat” not built up equal to the base metal thickness.



Workmanship = Craftsmanship

Weld Profiles

- ◆ This is an important aspect of welding. Statistics have proven that the weld profile is the cause for more weld failure than internal flaws.
- ◆ ***Reinforcement***
 - ◆ Minimum: Flush with base metal
 - ◆ Maximum: 1/8" high
- ◆ ***Bead Contour***
 - ◆ Smooth transition from bead to bead and weld metal to base metal.

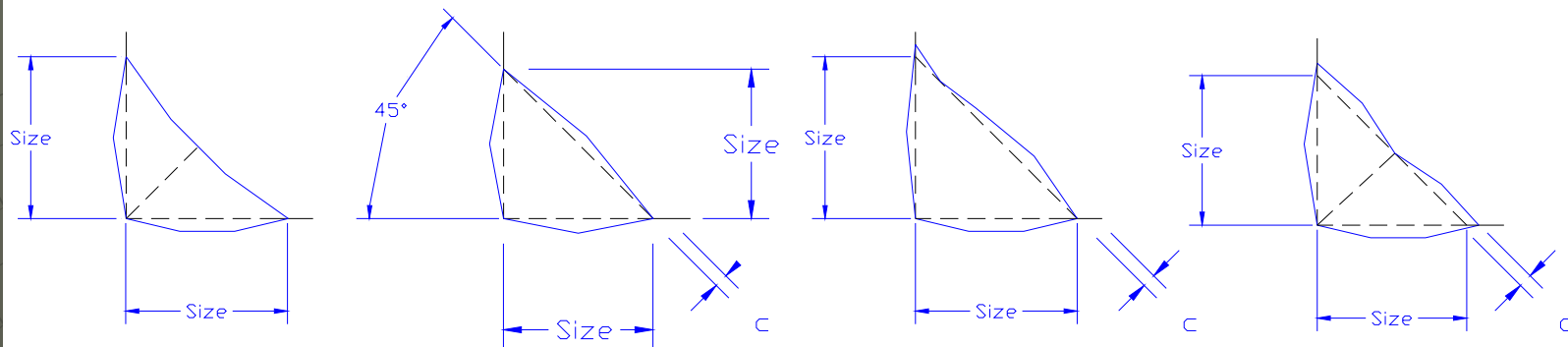

(A) Desirable Fillet weld profiles.

(B) Acceptable fillet weld profiles.

Width of weld face or individual surface Bead, W	max. convexity, c
$W \leq 5/16"$ (8MM)	$1/16"$ (1.6 MM)
$W > 3/8"$ to $W < 1"$ (25MM)	$1/8"$ (3MM)
$W \geq 1"$	$3/16"$ (5MM)

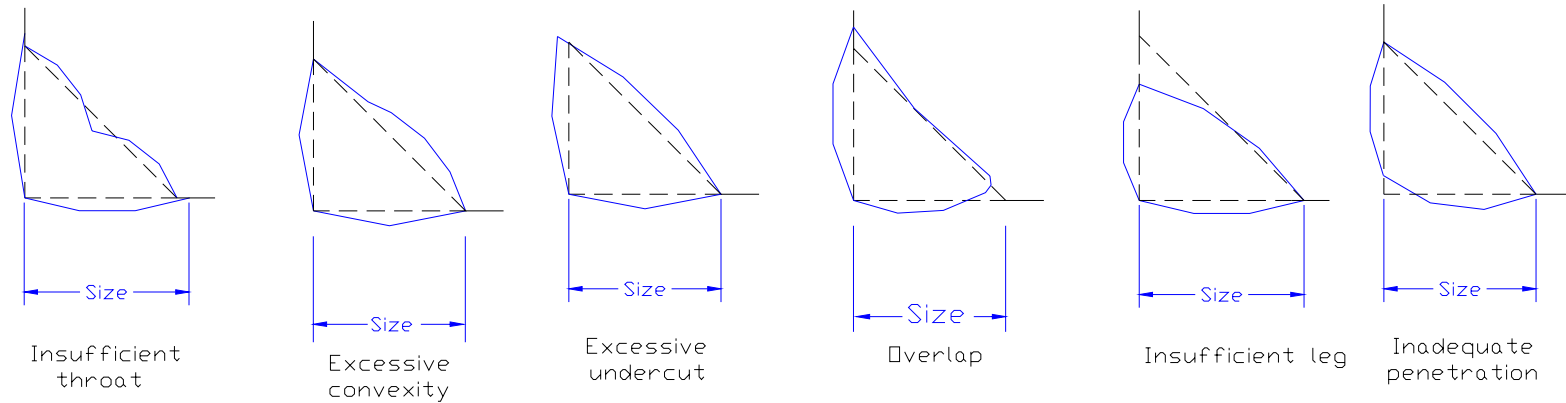

Unacceptable fillet weld profiles

Reference AWS D1.1

Groove Weld Information Sheet

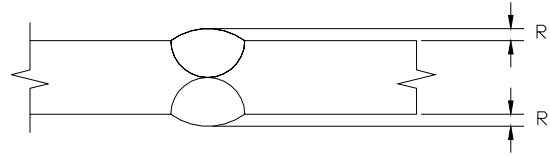

Acceptable butt weld profile.

NOTE: Reinforcement (R) shall not exceed 1/8".

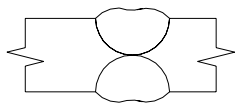

Excessive
Reinforcement

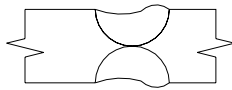

Insufficient
Weld Size

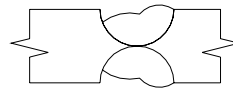

Excessive
Undercut

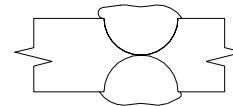

Overlap

Visual Inspection Tools

- ◆ Code or Standard
- ◆ Flash Light
- ◆ Tape Measure
- ◆ Fillet Weld Gage
- ◆ Weld Gage

Code or Standard

- ◆ Common Codes
 - AWS d1.1
 - API 1104
 - ASME Section IX
 - ASME Section VIII
 - ASME B31.
- ◆ What are the requirements you're working to????????????????????

Flash Light

- ◆ The use of a flash light can high light flaws that the inspector will find using the same tool.



Tape Measure

- ◆ The use of a tape measure is critical to the success in welding.
- ◆ More importantly the correct interpretation of a drawing with the correct use of a tape leads to success.



Fillet Weld Gage

- ◆ Select the size gage that is needed.
- ◆ Use the Concave side of the Fillet Weld Gage to measure leg size (see picture).
- ◆ The gage must be sitting flush on the metal to get an accurate measurement.
- ◆ **Note:** In this picture the weld leg is touching the tip of the weld gage. The weld equals the size of the gage.



Measuring Weld Reinforcement for a Groove Weld

- ◆ The weld gage is being used to measure weld reinforcement in this picture.
- ◆ The gage is positioned over the weld area and the pointer is extended to contact the weld. The pointer has an indicator line on it that can be read for reinforcement size.

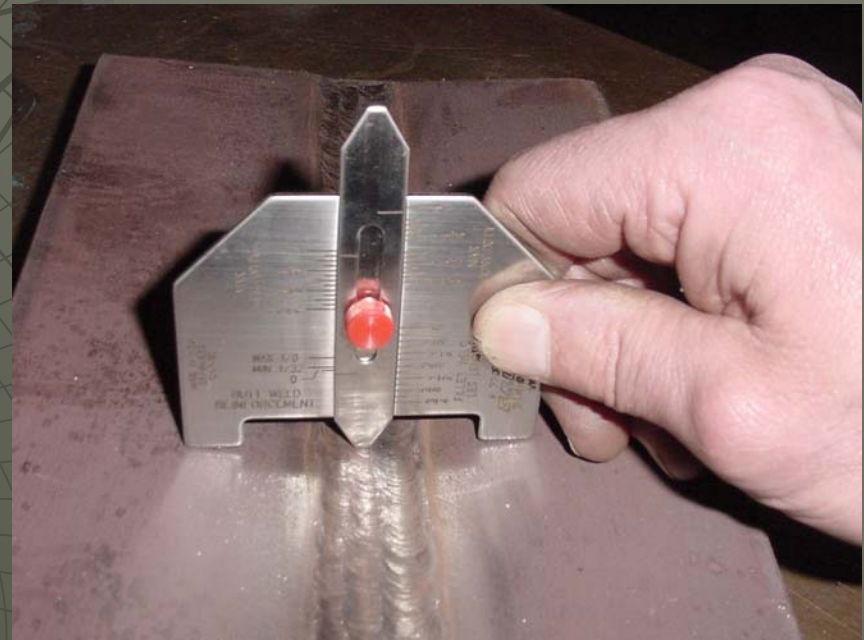

Measuring Weld Reinforcement for a Groove Weld

- ◆ Three pieces of 1/8" filler metal are being used to measure reinforcement. Although this is not a "scientific gage," it will assist in determining if there is too much reinforcement.

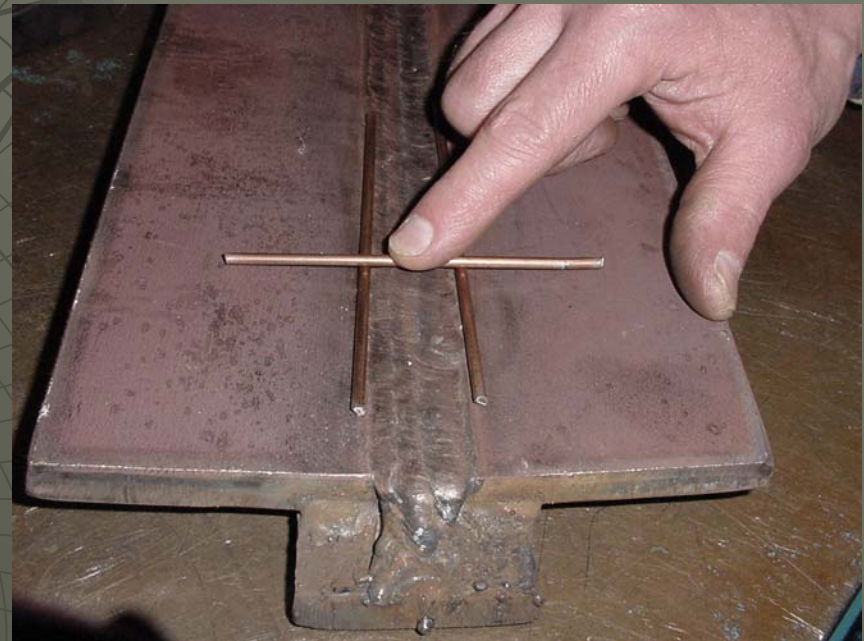

Keys to Quality

- ◆ Know and apply the requirements
- ◆ Use inspection tools if needed
- ◆ If in doubt.... Fix it!!!!!!
- ◆ Ask questions... You'll gain the respect of the inspector and fellow employees.
- ◆ Bragging will only lead to enhanced failure!!